

Main Application: Screen Printing

MAGIC 25



MAGIC 5000



MAGIC 7000



Features

This product is particularly suitable to operate with modern, automatic printing machines.

It is very easy to use and guarantees low operating costs and an excellent performance.

A professional product for the professionals in the printing industry.

- Heating is provided by super-quick start-up lamps with vacuum-filled tungsten filaments: a special feature increasing life and improving start-up time.
- The optical infrared thermometer reads the ink temperature instantly and stops the heating when the preset temperature has been reached, thus preventing the fabric burning. If temperature control cannot be used, traditional timing control is still available.
- Magic offers various types of starting action (mechanical or electronic), and also send a signal to the printing machine notifying the drying stage to be perfectly synchronized.
- Magic 25 has been designed for MHM machines. It can be installed directly on the printing machine and operate in synchrony.

Optionals

- Photoelectric cell starting controller
- Start cable for all printing machines
- Foot switch



Main Application: Screen Printing

TECHNICAL DATA	MAGIC 25 code: 1030033/71
Electrical Requirements	400V 3P + N + PE 19 A
Power Consumption	12 kw
Curing Area	600x420 mm
Working height	on printing machine
Number of Lamps	12
Overall Size (L x W x H)	630x510x260 mm
Shipping Weight	13 kg

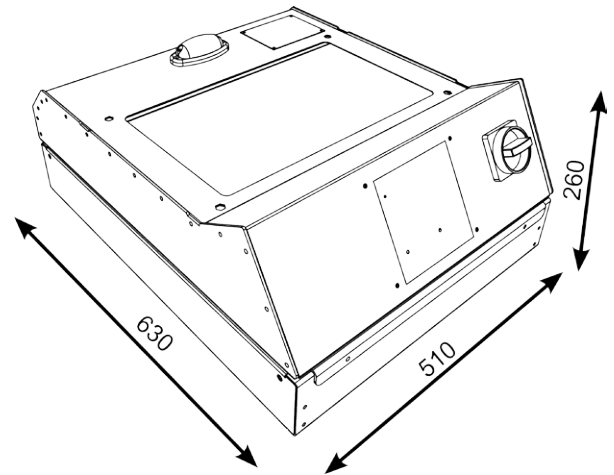

TECHNICAL DATA	MAGIC 5000 code: 1030019
Electrical Requirements	400V 3P + N + PE 13 A
Power Consumption	9 kw
Curing Area	500 x 500 mm
Working height	850 - 1050 mm
Number of Lamps	9
Overall Size (L x W x H)	1080x585x1250 mm
Shipping Weight	50 kg

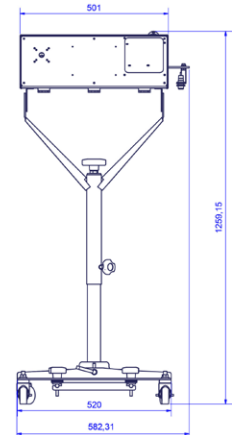
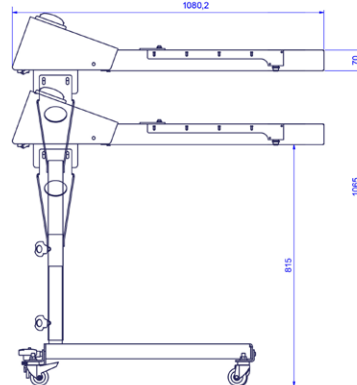
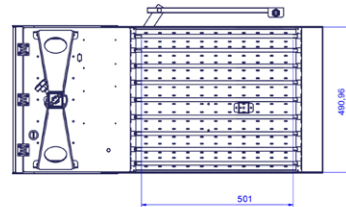

TECHNICAL DATA	MAGIC 7000 code: 1030020
Electrical Requirements	400V 3P + N + PE 19,5 A
Power Consumption	13 kw
Curing Area	500x700 mm
Working height	850 - 1050 mm
Number of Lamps	9
Overall Size (L x W x H)	1280x585x1250 mm
Shipping Weight	55 kg

