

## FLASH CURE FOR INTERMEDIATE DRYING SYSTEM



### OPTIONAL ACCESSORIES



CAVO START



CARRELLO DI SUPPORTO



FOTOCELLULA





Magic 25 control panel

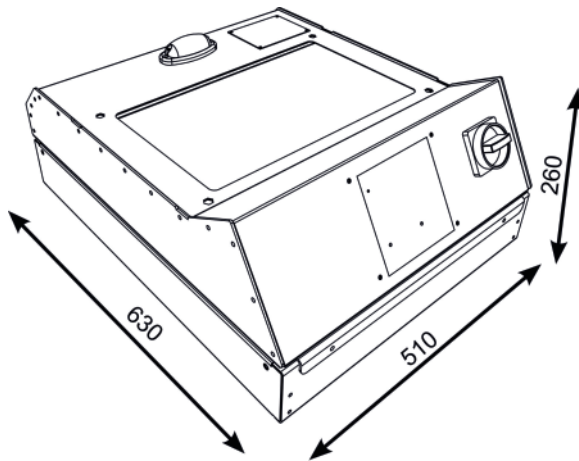

Magic 25 dimensions

## FEATURES

This product is particularly suitable for use on MHM printing machines. It ensures easy use, low consumption and high performance. An IR optics pyrometer instantly detects the ink temperature and stops the heating when the required temperature is reached, thereby preventing the fabric from burning. The traditional timed system can be used instead of the temperature control. Magic 25 works with photocell or start cable connected directly in the machine. It is possible to work with 6, 9 or 12 lamps, with the six central lamps always on.

## ADVANTAGES

The air circulation facilitates drying of all kinds of ink. The 12 lamps contained in Magic 25 are tungsten in vacuum, a special feature which increases the life and switching on speed. It can be installed in place of the printing panel on all those machines which do not have temporary halt. By working with temperature control, Magic 25 automatically reduces the switching-on times when the printing tables are heated.

## TECHNICAL DATA VALUES

<b>POWER SUPPLY</b>	<b>400 V + N + PE</b>
<b>POWER INPUT (max)</b>	<b>12 kW</b>
<b>LENGTH</b>	<b>630 mm</b>
<b>WIDTH</b>	<b>510 mm</b>
<b>HEIGHT</b>	<b>260 mm</b>
<b>NUMBER OF LAMPS</b>	<b>12</b>
<b>WEIGHT</b>	<b>13 kg</b>