

Main Application: Screen Printing

## MAGIC 25



## MAGIC 5000



## MAGIC 7000



## Features

This product is particularly suitable to operate with modern, automatic printing machines.

It is very easy to use and guarantees low operating costs and an excellent performance.

A professional product for the professionals in the printing industry.

- Heating is provided by super-quick start-up lamps with vacuum-filled tungsten filaments: a special feature increasing life and improving start-up time.
- The optical infrared thermometer reads the ink temperature instantly and stops the heating when the preset temperature has been reached, thus preventing the fabric burning. If temperature control cannot be used, traditional timing control is still available.
- Magic offers various types of starting action (mechanical or electronic), and also send a signal to the printing machine notifying the drying stage to be perfectly synchronized.
- Magic 25 has been designed for MHM machines. It can be installed directly on the printing machine and operate in synchrony.

## Optionals

- Photoelectric cell starting controller
- Start cable for all printing machines
- Foot switch



## Main Application: Screen Printing

TECHNICAL DATA	Magic 25 code 1030033 / 71
Power Supply	400V 3P+N+PE
Power Consumption	12 kw - 19A
Curing Area [mm]	600x420
Working Height [mm]	on printer
Number of Lamps	12
Size (L x W x H <sup>1</sup> ) [mm]	630 x 510 x 1260
Shipping Weight	13 kg

<sup>1</sup> Overall height may change accordingly to support adjustments

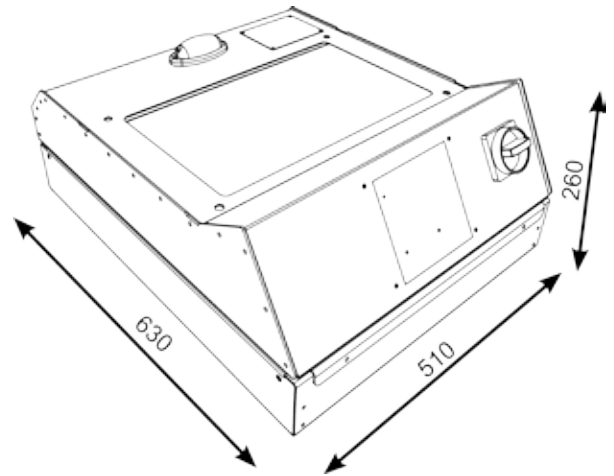

TECHNICAL DATA	Magic 5000 code 1030019
Power Supply	400V 3P+N+PE
Power Consumption	9 kw - 13 A
Curing Area [mm]	500x500
Working Height [mm]	850 - 1050
Number of Lamps	9
Size (L x W x H <sup>1</sup> ) [mm]	1038x520x1260
Shipping Weight	50 kg

<sup>1</sup> Overall height may change accordingly to support adjustments

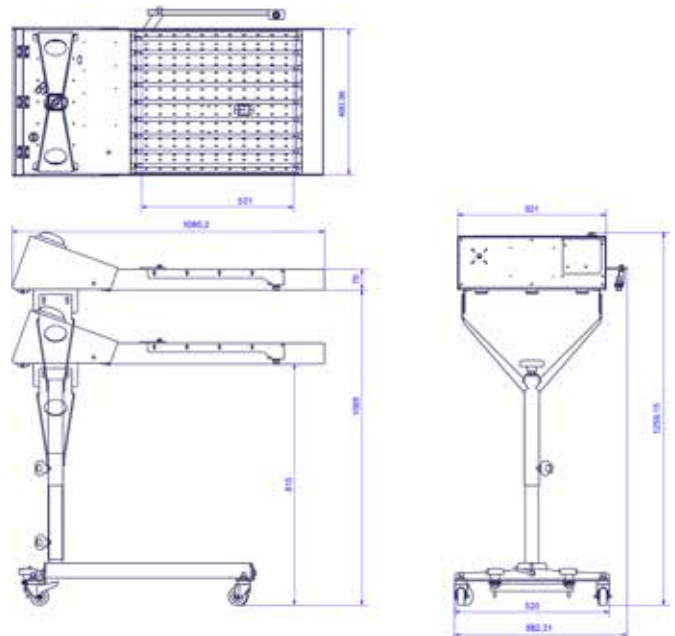

TECHNICAL DATA	Magic 7000 code 1030020
Power Supply	400V 3P+N+PE
Power Consumption	13 kw - 19,5 A
Curing Area [mm]	500x700
Working Height [mm]	850 - 1050
Number of Lamps	9
Size (L x W x H <sup>1</sup> ) [mm]	1238x520x1260
Shipping Weight	55 kg

<sup>1</sup> Overall height may change accordingly to support adjustments

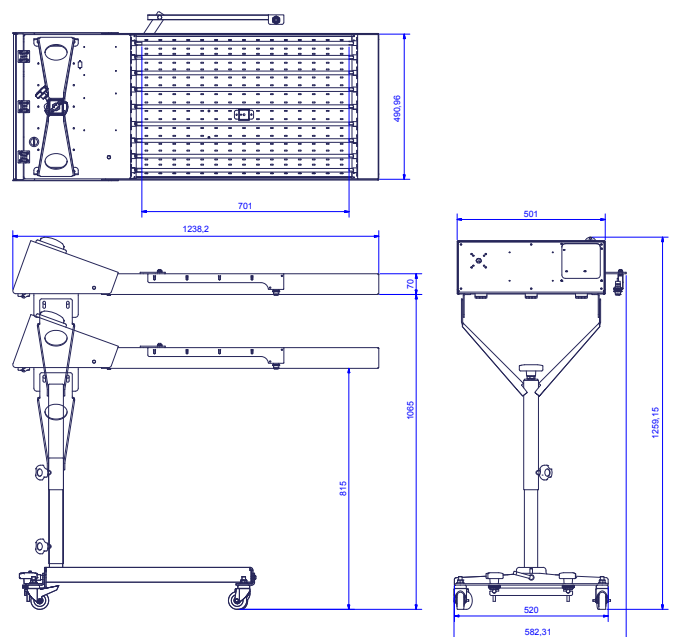

The data in this document was valid at the time of publishing, and is subject to change without notice. Chiossi e Cavazzuti srl reserves the right to modify its products and change their specifications at any time, without prior notice and further obligation. It is forbidden without prior authorization from Chiossi e Cavazzuti srl to copy, modify, alter, publish, distribute, sell or transfer this material. All rights reserved.