

# DUAL I200

Modular Electric Dryers with Forced Hot Air

Main Application: DTG Digital Printing - Industrial production



code: **1390034**

**Production:** Water-based Digital Ink – A4 print size on T-shirt

3 minutes curing time: 270 pieces/h  
 4 minutes curing time: 200 pieces/h  
 5 minutes curing time: 160 pieces/h  
 6 minutes curing time: 140 pieces/h

Data may change according to fabric material, drying area size and ink curing requirements.

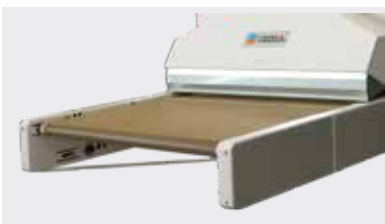
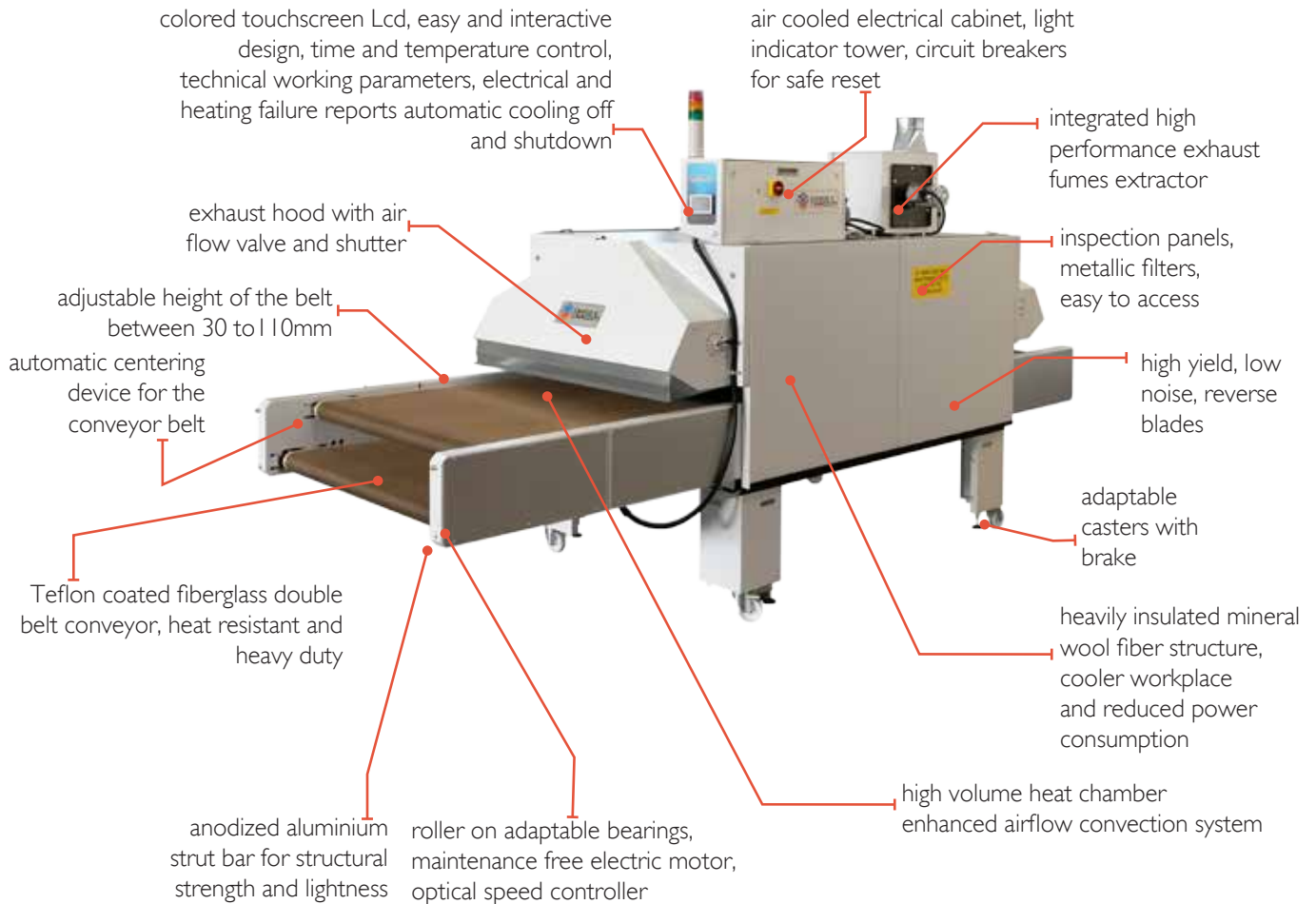

### Single conveyor belt

Basic configuration



### Returning conveyor belt

Load and unload in the same position, available as optional



### Double conveyor belt

Cure with different time simultaneously

TECHNICAL DATA	DUAL I200
Power Supply	400V 3P+PE (208V/230V 3P+PE optional)
Power Consumption <sup>1</sup>	19 kW - 29A
Max Temperature	180°C
Exhaust Specification	180 m <sup>3</sup> /h - Ø 150 mm
Tunnel Length	2000 mm
Belt Width [mm]	1200
Production <sup>2</sup> (light-dark)	240 - 160 pieces/h
Dimension <sup>3</sup> (LxWxH)[mm]	4150 x 1500 x 2250
Shipping Weight <sup>3</sup>	780 kg

<sup>1</sup> Max Power consumption during first heating cycle. Working consumption is about 60% of max value, depending on environmental conditions.

<sup>2</sup> Production of L size T-shirts with A4 size DTG print - 4 minutes curing time for light garments - 6 minutes curing time for dark garments. Production data consider the loading side by side of 1 product for 600mm belt, 2 for 950mm, 3 for 1200mm and 4 for 1900mm belt.

<sup>3</sup> Dimension and Weight can change accordingly to inlet/outlet extensions or installed optionals.

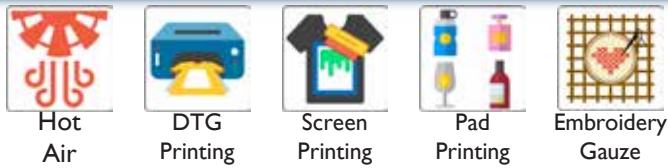

code: **1390034**

## FEATURES AND ADVANTAGES

- **Specifically designed to cure and dry digital printing on fabrics**, the massive advantage of this Dryer is the high volume of forced air circulation: this facilitates and accelerates the evaporation of water-based digital inks with unmatched results on the finished garment in medium-long drying process.
- **In the heat chamber the temperature is uniform and constant on both sides and the center**, adjusted by a precise thermostat and by a long lasting static relay control system; in this manner the temperature never exceeds the set value, preventing damage even to the most delicate fabrics.
- **Heavily insulated mineral-wool fiber structure** results in a cooler workplace and cool to the touch external skin. Remarkably it reduces both power consumption and heat dissipation.
- **The returning belt conveyor** allows the operator to work without having to change his position; the belt conveyor below works at lower temperatures; this improves curing quality and at the same time allows the operator to touch the printed garment without burning risk.
- **The double belt conveyor configuration allows to operate simultaneously with two independent curing time**. Each belt has its own speed control to be adjusted in relation to the ink or garment need.
- **The air exchange is adjusted to discharge steam and promote high volume air circulation**. This enhanced airflow convection system is designed on purpose and employs high yield low noise reverse blades.
- **Speed, Time and Temperature control are processed digitally for precise and fast adjustments**. The automatic cooling off and shutdown can be set on demand to suit different working necessities; dryer technical parameters, real-time energy consumption and alarm notifications are clearly displayed.
- **The Optional Cooling Hood at the outfeed of the Dryer** is an effective cooling system to protect both the operator and delicate products from high temperatures, after the drying process has ended.

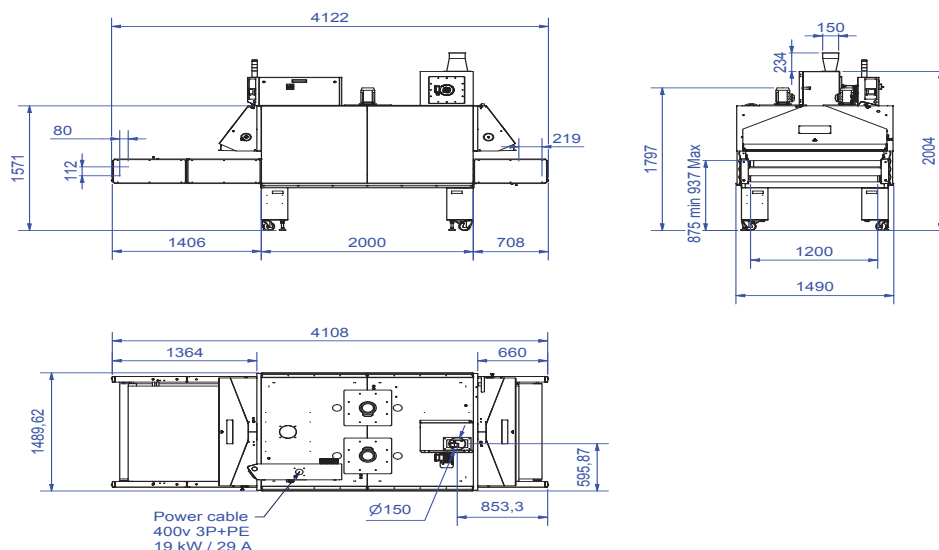

The data in this document was valid at the time of publishing, and is subject to change without notice. Chiossi e Cavazzuti srl reserves the right to modify its products and change their specifications at any time, without prior notice and further obligation. It is forbidden without prior authorization from Chiossi e Cavazzuti srl to copy, modify, alter, publish, distribute, sell or transfer this material. All rights reserved.